

# fiberhome

## Protection housing

The fiberhome protection housing is designed as a laser protection class 1 table-top model. Either fiber laser DP10F or DP20F can be fitted, as required. The manually operated unit is suitable for processing single parts and small series.

### Advantages

- Compact construction
- Processing area  
420 x 320 [mm]
- Motor-driven Z-axis with  
250 mm stroke
- With illumination, integrated  
camera and vacuuming  
connection as standard
- Extremely cost-effective



# fiberhome

## Protection housing

### Housing

Load	Workpieces up to 20 kg
Processing area	420 x 320 [mm]
Z-axis (focus)	250 mm
Vacuuming connection	
Illumination	
Camera	

### Laser

Laser type	Pulsed Yb Fiber Laser, 1060 -1070 nm, diode pumped DP10F / DP20F
Marking field	110 x 110 mm <sup>2</sup> (f=160 mm)
Marking speed	up to 5000 mm/s up to 500 characters/s
Line width	50 µm
Power (QS)	typ. 9 W (20 kHz) / typ. 18 W (20 kHz)
Power stability	+/- 1 %
Pulse frequency	20 - 100 kHz
Pulse energy	0.45 mJ (20 kHz) / 0.9 mJ (20 kHz)
Pulse width	110 ns (20 kHz)

### Control

PC	CompactPCI-PC
Operating system	MS Windows <sup>®</sup> 2000
Laser control	FOBAGRAF with Import functions of plt/dwg/dxf/ai/jpg/tif/pcx/bmp u.a.
Interfaces	serial, digital I/O, Ethernet, USB

### Installation

Electrical	L/N/PE, AC 100 - 138 V, 187 - 240 V, adjustable, 50/60 Hz
Power consumption	typ. 400 W / typ. 600 W
Cooling system	forced air
Temperature	15 - 40 °C
Humidity	90 % (up to max. 20 °C) 30 % (up to max. 40 °C) non-condensing
Weight	Housing with laser approx. 95 kg Control approx. 15 kg Monitor, keyboard, mouse approx. 10 kg
Degree of protection	IP 43
Laser safety	Laser class 1

### Options

Safety windows	in lifting door
Axis of rotation	with servodrive

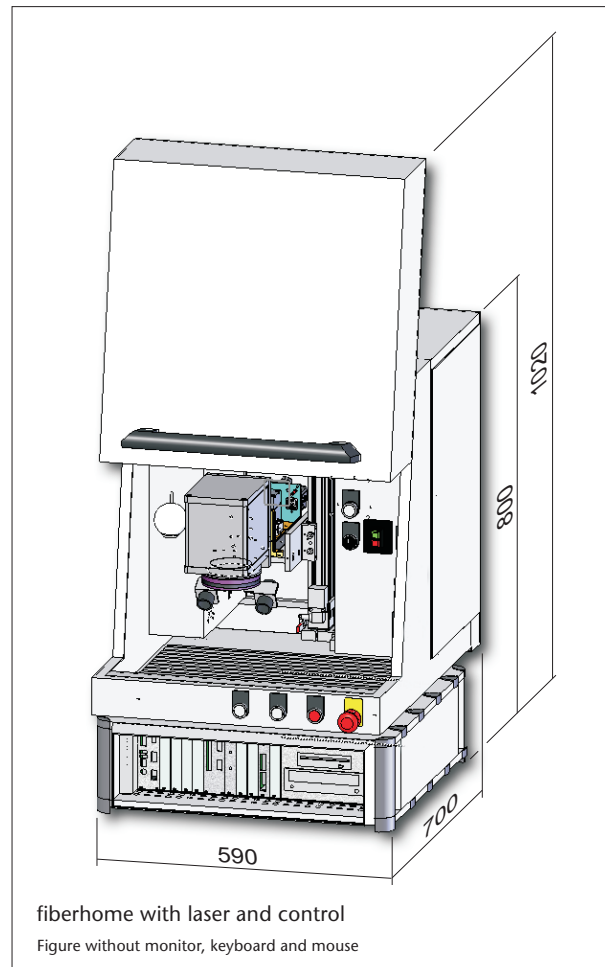

fiberhome with laser and control  
Figure without monitor, keyboard and mouse

End to end excellence in laser systems

**FOBA<sup>®</sup>**  
Laser Marking + Engraving  
A Virtek Company



#### EUROPE

FOBA Technology + Services GmbH  
www.foba.de  
sales@foba.de

Postfach 15 60  
D-58465 Lüdenscheid  
Germany

Tel. +49 2351 996-0  
Fax +49 2351 996-155

#### NORTH & SOUTH AMERICA

Virtek  
www.virtek.ca  
fobasales@virtek.ca

785 Bridge Street  
Waterloo, ON N2V 2K1  
Canada

Tel. +1 800 684-7835 or 519 746-7190  
Fax +1 519 746-3383

#### ASIA

Virtek Asia Pacific Inc.  
www.virtek.ca  
asia.sales@virtek.ca

Eru Building, 2<sup>nd</sup> Floor  
3-14-6 Higashikashiwagaya  
Ebina City, Kanagawa, 243-0401, Japan

Tel. +81 46-292-0739  
Fax +81 46-292-0793